

THIS DRAWING IS UNPUBLISHED. RELEASED FOR PUBLICATION  
 © COPYRIGHT - By - ALL RIGHTS RESERVED.

| LOC | DIST | REVISIONS   |      |                           |         |    |     |
|-----|------|-------------|------|---------------------------|---------|----|-----|
| P   | LTR  | DESCRIPTION | DATE | DWN                       | APVD    |    |     |
|     |      | P           |      | REVISED PER ECO-11-005030 | 11MAR11 | RK | HMR |

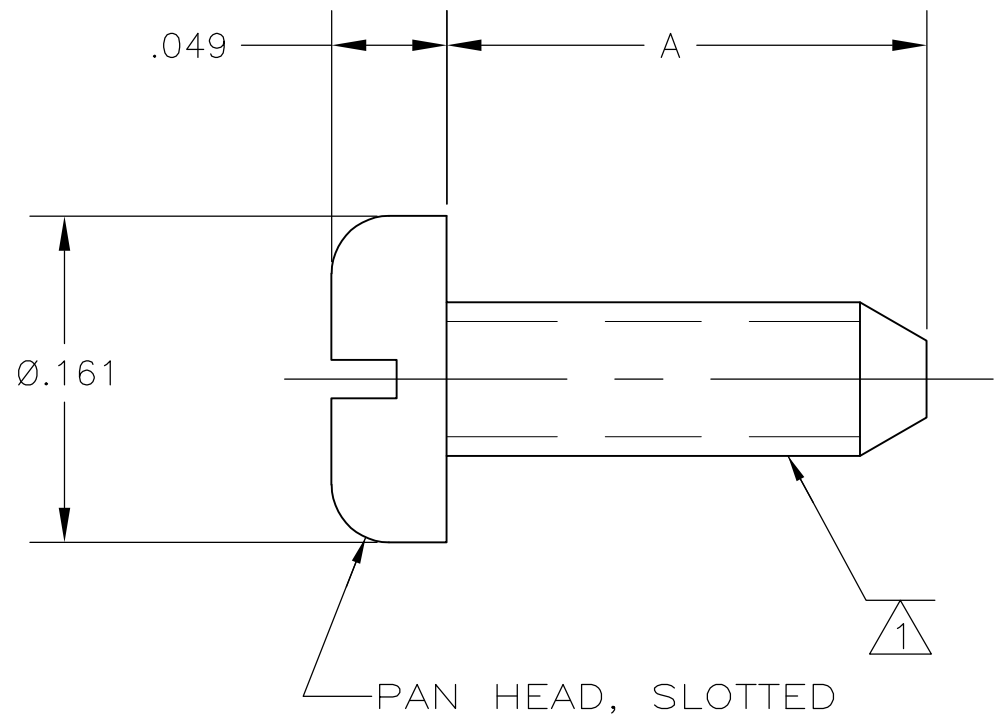

- ① #2-56 SPECIAL THREAD-ROLLING SCREW THREAD
- ② CARBON STEEL PER AISI 1019-1022
- ③ ZINC PLATE

|          |            |
|----------|------------|
| .250 MAX | 9-221108-1 |
| .312 MAX | 9-221108-0 |
| .250 MAX | 221108-4   |
| .312 MAX | 221108-2   |
| A DIM    | PART NO    |

|   |        |                  |            |               |                            |            |     |       |        |       |     |        |     |              |  |                     |  |  |
|---|--------|------------------|------------|---------------|----------------------------|------------|-----|-------|--------|-------|-----|--------|-----|--------------|--|---------------------|--|--|
| THIS DRAWING IS A CONTROLLED DOCUMENT.  |        | DWN              | M SYKES    | 02JUN2006     | <b>STE</b> TE Connectivity |            |     |       |        |       |     |        |     |              |  |                     |  |  |
| DIMENSIONS:<br>INCHES   |        | CHK              | DK SCHRUM  | 02JUN2006     |                            |            |     |       |        |       |     |        |     |              |  |                     |  |  |
| TOLERANCES UNLESS OTHERWISE SPECIFIED:  |        | APVD             | JT LIPPERT | 02JUN2006     | NAME                       |            |     |       |        |       |     |        |     |              |  |                     |  |  |
| <table border="0"> <tr><td>0 PLC</td><td>± -</td></tr> <tr><td>1 PLC</td><td>± -</td></tr> <tr><td>2 PLC</td><td>± -</td></tr> <tr><td>3 PLC</td><td>± .008</td></tr> <tr><td>4 PLC</td><td>± -</td></tr> <tr><td>ANGLES</td><td>± -</td></tr> </table> |        | 0 PLC            | ± -        | 1 PLC         | ± -                        | 2 PLC      | ± - | 3 PLC | ± .008 | 4 PLC | ± - | ANGLES | ± - | PRODUCT SPEC |  | SCREW, SELF TAPPING |  |  |
| 0 PLC   | ± -    |                  |            |               |                            |            |     |       |        |       |     |        |     |              |  |                     |  |  |
| 1 PLC   | ± -    |                  |            |               |                            |            |     |       |        |       |     |        |     |              |  |                     |  |  |
| 2 PLC   | ± -    |                  |            |               |                            |            |     |       |        |       |     |        |     |              |  |                     |  |  |
| 3 PLC   | ± .008 |                  |            |               |                            |            |     |       |        |       |     |        |     |              |  |                     |  |  |
| 4 PLC   | ± -    |                  |            |               |                            |            |     |       |        |       |     |        |     |              |  |                     |  |  |
| ANGLES  | ± -    |                  |            |               |                            |            |     |       |        |       |     |        |     |              |  |                     |  |  |
| MATERIAL  |        | APPLICATION SPEC |            | RESTRICTED TO |                            |            |     |       |        |       |     |        |     |              |  |                     |  |  |
| FINISH  |        | WEIGHT           |            | SIZE          | CAGE CODE                  | DRAWING NO |     |       |        |       |     |        |     |              |  |                     |  |  |
| ②   |        | ③                |            | A3 00779      |                            | C-221108   |     |       |        |       |     |        |     |              |  |                     |  |  |
| CUSTOMER DRAWING  |        |                  |            | SCALE         | SHEET                      | REV        |     |       |        |       |     |        |     |              |  |                     |  |  |
|   |        |                  |            | NTS           | 1 OF 1                     | P          |     |       |        |       |     |        |     |              |  |                     |  |  |